



HOSPITAL OVERBED TABLES

For **EV5202** and **EV5203**



EV5202CP
Compact Laminate,
Parchment with
Cream base

Overbed Tables

EV5202 (Cream Base)

EV5203 (Gun Metal Grey with Hammertone Finish)

Premium Overbed tables

Thank you for purchasing this Evocare Overbed Table. It is strongly recommended that you read through this user manual prior to using your Overbed Table for the first time. Your Overbed Table should provide years of trouble-free use, provided that you adhere to these recommendations.

WE ARE HERE TO HELP YOU

To request product service and order replacement parts, please call:

Customer Service: 07 3355 8000

Spare Parts: 07 3355 8007

8.30 am to 5.00 pm Monday to Friday

Email: sales@[evocare.com.au](mailto:sales@evocare.com.au)

If the product does not function properly contact [Evocare](#) Australia.

When requesting service, please provide the following information:

1. Part Code and Description
2. Date of Purchase

Address: Evocare Australia Pty Limited
260 South Pine Road, Enoggera, Qld. 4051
P.O. Box 1144, Stafford, Qld. 4053

DESCRIPTION

Overbed Tables

EV5202 (Cream Base), EV5203 (Grey Base) Premium Over bed tables with a 13mm Compact Laminate top

Features:

- Two styles of Server Tops are available:
 - Server tops approx. 765 x 385 x 19mm, rounded corners of 19mm FPY board with both sides of melamine
 - Server tops approx. 765 x 385 x 13mm made of compact laminate.
- Clearance to the top of the base frame is 90mm, for use under low beds.
- 50mm twin wheel castors, 2 x swivel, 2 locking
- Table Top Dimensions: 765mm x 385mm
- High /Low Adjustment: 715mm to 1145mm
- Safe Working Load (SWL): 10 kg
- Overbed Table Weight: 4 kg
- Spring loaded height adjustment with lever action.
- Single handed height adjustment with **lever** lock mechanism.
- Painted base, chrome column.
- **ARTG No:229804**

Standard Top Colours to match Stieglmeyer Beds



Beech



Grey Anthracite



Tool for assembly



Lever and securing bolt



Beige Grey



Lindberg Oak



Base to column attaching bolts with spacers and plate



Bolts to attach column to table top

ASSEMBLY

ASSEMBLY

***** DO NOT use if damaged. *****

Overbed Table Assembly

.Position column upside down and insert release lever. (The release rod inside the column should be visible in the lower portion of the column. If not shake the column).

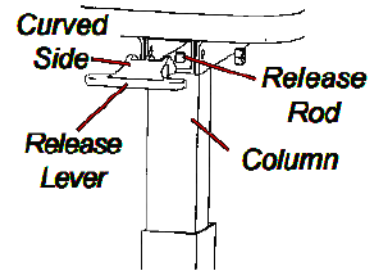

.The curved side of the of the release lever should be closest to the top of the table and between the release rod and the column.

.Put table top upside down on a flat surface.

.Hold release lever in column and locate into top bracket—align holes—install bolts, first through top bracket, column and release lever, then second through top bracket and column. Tighten locknuts.

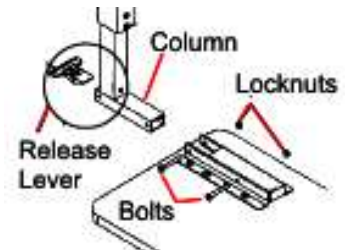

.Install a bolt through the bolt plate and column—hand tighten—repeat for other side.

.Put overbed table on its side to ease pressure on the bolts—align column and base and tighten both bolts.

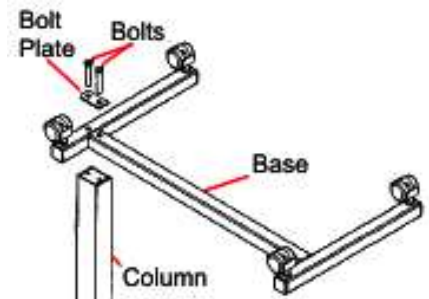

.Remove the shipping screw (top screw, DO NOT REMOVE THE OTHER SCREW) from the column and replace with Phillips screw provided.

.The Overbed Table can now be adjusted to the desired height.

.To RAISE the table top, place your hand underneath the table top and move it upward to the desired height. Remove hand pressure to set height.

.To LOWER the table top, lift the release lever and push the table top downward to the desired height. Let go of the release lever to set height.

(The column locks in place when the release lever is released.)

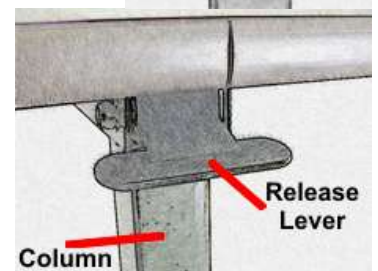

You are now ready to use your **Evocare** Overbed Table

SAFETY

SAFETY:

WARNING: *Be sure to read all information and directions before use!!*

If you are unable to understand the warnings or instructions contact a therapist or dealer before using the Overbed Table, otherwise injury or damage may result.

▲ If the Overbed Table is not properly assembled and installed, injury and damage to the Overbed Table could result.

▲ If components are damaged or missing, contact your dealer immediately. DO NOT use substitute parts.

▲ **WARNING** Adjustable overbed tables have a powerful internal spring. Do not disassemble the table or loosen any screws. Exercise extreme caution when working near the spring.

▲ Do regularly check frame screws to ensure they are tight.

▲ Regularly check castors roll freely and locks work.

▲ Regular cleaning and inspection is recommended with a damp cloth and mild soapy water or non-abrasive cleaner.

The Evocare Overbed Table's construction allows for easy cleaning.

1. Evocare provides consumers with the following warranty in relation to this Product, in addition to complying with the requirements of any relevant legislation, including the *Competition and Consumer Act 2010* (Cth) in Australia and the *Consumer Guarantees Act 1993* in New Zealand (the Acts), except where a New Zealand consumer acquires the Product for the purposes of a business.
2. In this warranty, we have used the following definitions:
 - (a) **Form** means a warranty claim form issued by Evocare in respect of Products;
 - (b) **Evocare or our** means Evocare Australia Pty Limited, ABN 98 078 566 604 of Level 19, 144 Edward Street, Brisbane 4000;
 - (c) **Products** means the goods manufactured for Evocare (including products manufactured by its contract manufacturers);
 - (d) **Material** means a material or component used by Evocare in the manufacture of the Products;
 - (e) **Retailer** means the authorised dealer of Products from whom the Product was purchased;
 - (f) **Warranty Period** means the warranty period commencing from the date of purchase of the relevant Product. If the Product or part (as the case may be) is repaired or replaced, there will be no extension to the original warranty period; and
 - (g) **Workmanship** means the handling, assembly and manufacturing processes performed by or on behalf of Evocare in order to manufacture the Products.
3. Evocare warrants that for the duration of the Warranty Period, all Products will be free of faults arising from defects in Workmanship or Materials, on the terms and conditions set out in this warranty.
4. Evocare undertakes that if during the Warranty Period any Product, or any part of a Product, has failed to operate correctly due to faulty Workmanship or defective Material, it will repair or replace the Product or part (as the case may be) free of charge provided that the following procedures are met :
 - (a) The consumer must contact the Retailer or Evocare upon becoming aware of any defect to a Product upon which the consumer will be required to complete a Form and provide satisfactory proof of purchase.
 - (b) Evocare will review the Form to determine whether there is a defect, and if so Evocare agrees to (at its option) repair, replace or supply equivalent goods, or pay the cost of any of those remedies to the consumer.
 - (c) If Evocare requests the return of the applicable Product or part, the consumer will be responsible for the collection and freight costs of returning that Product or part to Evocare.
 - (d) The consumer acknowledges that it is also responsible for the freight costs to deliver any new Product or replacement part to it.
5. This warranty is in addition to any non-excludable legal rights or remedies conferred on the consumer under any applicable Act and any similar laws. To the extent permitted by law, Evocare's liability for any non-excludable condition or warranty is limited to rectifying any defect at its option, as set out in paragraph 4(b).
6. Subject to the requirements of any applicable Act or legislation and to the extent permitted by law, no liability (whether expressed or implied) of any nature whatsoever, is accepted by Evocare for any consequential loss, damage or injury arising as a result of any fault in the Products.
7. This warranty does not extend to damage to Products which occurs during transit or transportation, or which is caused by any abuse, accident or improper installation, connection, use, adjustment or repair or use of goods otherwise than in accordance with instructions issued by Evocare.
8. The warranty on Products is waived if any addition or attachment to the Products do not have Evocare's approval or are not sold as Evocare products. The Products are designed to perform specific tasks under established test loads and unauthorised attachments may produce stresses for which the design is not appropriate.
9. The following applies to consumers who purchased a relevant Product in Australia:

Our goods come with guarantees that cannot be excluded under the Australian Consumer Law. You are entitled to a replacement or refund for a major failure and compensation for any other reasonably foreseeable loss or damage. You are also entitled to have the goods repaired or replaced if the goods fail to be of acceptable quality and the failure does not amount to a major failure.

WARRANTY

Evocare warrants this Premium Overbed Table, against faulty workmanship, for a period of twelve months.

NOTE: This does not include staining, accidental damage from misuse and abuse or neglect or when used for a purpose for which it was not designed.

Evocare must inspect the product within the warranty period for any claims lodged.

Evocare warranty does not cover product that has been modified from its original form.

For more information about your Evocare Overbed Table warranty or to order parts call 07 3355 8007.

E- mail: sales@evocare.com.au

Website www.evocare.com.au

Manufactured for:

Evocare Australia Pty Limited, 260 South Pine Road, Enoggera. QLD. 4051.

Phone: 07 3355 8000

FAX: 07 3355 5043

CLEANING & MAINTENANCE

Regular cleaning and inspection is recommended.

The Overbed Table is maintenance free provided all instructions are followed.

All parts can be cleaned with a damp cloth, warm soapy water or a neutral non-abrasive cleanser.