



Transport Wheelchair—Aluminium Frame



LM9712

Thank you for purchasing this Transport Wheelchair. It is strongly recommended that you read through this user manual prior to using your Transport Wheelchair for the first time. Your Transport Wheelchair should provide years of trouble-free use, provided that you adhere to these recommendations.

WE ARE HERE TO HELP YOU

To request product service and order replacement parts, please call:

Customer Service: 07 3355 8000

Spare Parts: 07 3355 8007

8.30 am to 5.00 pm Monday to Friday

Email: sales@[evocare.com.au](mailto:sales@evocare.com.au)

If the product does not function properly contact [Evocare](#) Australia.

When requesting service, please provide the following information:

1. Part Code and Description
2. Date of Purchase

Address: Evocare Australia Pty Limited
260 South Pine Road, Enoggera, Qld. 4051
P.O. Box 1144, Stafford, Qld. 4053

DESCRIPTION

Transport Wheelchair



Note: Maximum user weight for this wheelchair is **100kg**

Evocare is a quality endorsed company and supplies equipment listed with the Therapeutic Goods Administration.
The ARTG number for the LM9712 Transport Wheelchair is 175495.

Safety / Handling of Transport Wheelchairs

Safety and handling of the transport wheelchair requires the close attention of the transport wheelchair user as well as the assistant. This manual points out the most common procedures and techniques involved in the safe operation and maintenance of the transport wheelchair. It is important to practice and master these safe techniques until you are comfortable in manoeuvring around the frequently encountered architectural barriers.

Use this information only as a basic guide. The techniques that are discussed on the following pages have been used successfully by many users.

Individual transport wheelchair users often develop skills to deal with daily living activities that may differ from those described in this manual. All warnings and cautions given in this manual **MUST** be followed.

Techniques in this manual are a starting point for the new transport wheelchair user and assistant with safety as the most important consideration for all.

Stability and Balance

To assure stability and proper operation of your transport wheelchair, you must at all times maintain proper balance. Your transport wheelchair has been designed to remain upright and stable during normal daily activities as long as you do not move beyond the centre of gravity.

Virtually all activities which involve movement in the transport wheelchair have an effect on the centre of gravity. Use the adjustable seatbelt for additional safety.

DO NOT lean forward out of the transport wheelchair any further than the length of the armrests. Make sure the castors are pointing in the forward position whenever you lean forward. This can be achieved by advancing the transport wheelchair and then reversing a little in a straight line.

Operating Instructions

To determine and establish your particular safety limits, practice bending, reaching and transferring activities in several combinations in the presence of a qualified health professional before attempting active use of the transport wheelchair.

ALWAYS check hand grips for looseness before using the transport wheelchair. If loose and/or worn, replace immediately.

If the transport wheelchair is exposed to extreme temperature (above 38°C or below 0°C), high humidity and/or becomes wet, prior to use, ensure hand grips DO NOT twist on the transport wheelchair handle—otherwise damage or injury may occur.

DO NOT attempt to reach objects if you have to move forward in the seat as this may tip the wheelchair.

DO NOT attempt to reach objects if you have to pick them up from the floor by reaching down between your knees as this may tip the wheelchair.

DO NOT lean over the top of the back upholstery to reach objects behind you, as this may tip the wheelchair.

DO NOT shift your weight or sitting position toward the direction you are reaching, as this may tip the wheelchair.

DO NOT tilt the transport wheelchair without assistance.

DO NOT use an escalator to move a wheelchair between floors—serious injury may occur.

NEVER leave an unoccupied transport wheelchair on an incline.

DO NOT attempt to stop a moving transport wheelchair with the wheel locks. Wheel locks are not brakes.

Before attempting to transfer in or out of the transport wheelchair, every precaution should be taken to reduce the gap distance. Turn both castors parallel to the object you are transferring onto. When transferring to and from the transport wheelchair, ALWAYS lock both hand brakes (locks) before transferring to and from the transport wheelchair.

DO NOT sit or transfer into the transport wheelchair unless it is fully open.

DO NOT operate on roads, streets or highways.

DO NOT climb, go up or down ramps or traverse slopes greater than 9°.

DO NOT attempt to move up or down an incline which has a film of water, ice or oil on it.

DO NOT attempt to ride over kerbs or obstacles. Doing so may cause your transport wheelchair to tip, causing bodily harm or damage to the wheelchair.

DO NOT over tighten hardware attaching to the frame. This could cause damage to the frame tubing.

Using the Stepper Tube

Use the stepper tube to raise the front castors (when mounting a low kerb for example). To use, push down on the stepper tube with your foot. **DO NOT** raise the front castors by pushing down on the push handles as this could tip the wheelchair.

To mount a low kerb. Approach the low kerb head on. Then the assistant uses the stepper tube to raise the front castors, and lowers the front castors on the raised kerb. Finally the assistant should push the wheelchair forward, lifting it up slightly to mount the kerb if required.

To go down a low kerb. Line up the front castors with the edge of the low kerb. The assistant uses the stepper tube to raise the front castors and tip the users back slightly. Keeping the castors raised slowly move the wheelchair forward and slowly lower it down the low kerb.

Warning: When going down a low kerb, the front castors must be raised to prevent the user from falling forward. The above are only recommendations and may not be suitable for all events.

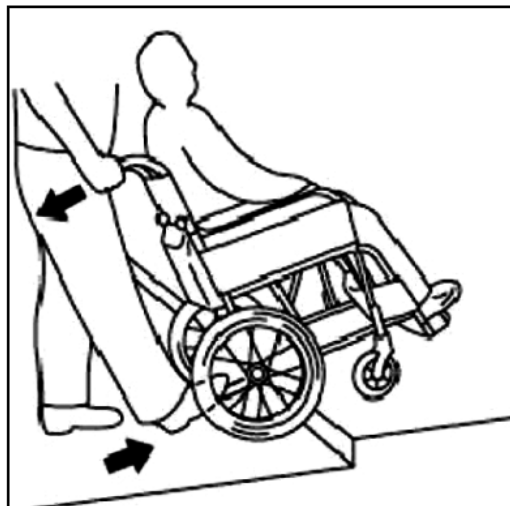

OPERATION

WARNING

After any adjustments, and before use, make sure all attaching hardware is tightened securely. Otherwise, injury or damage may result.

Installing Swingaway Removable Legrest Assembly

NOTE: For this procedure refer to FIGURE 1.

1. Turn the footrest to the side (open footplate perpendicular to transport wheelchair).
2. Install the hinge plates on the footrest onto the hinge pins on the transport wheelchair frame.
3. Push the footrest towards the inside of the transport chair until it locks into place.

NOTE: The footplate will be on the inside of the transport wheelchair when locked in place.

4. Repeat this procedure for the other footrest assembly.
5. To release the footrest, push the footrest release lever inward, rotate the footrest outward.

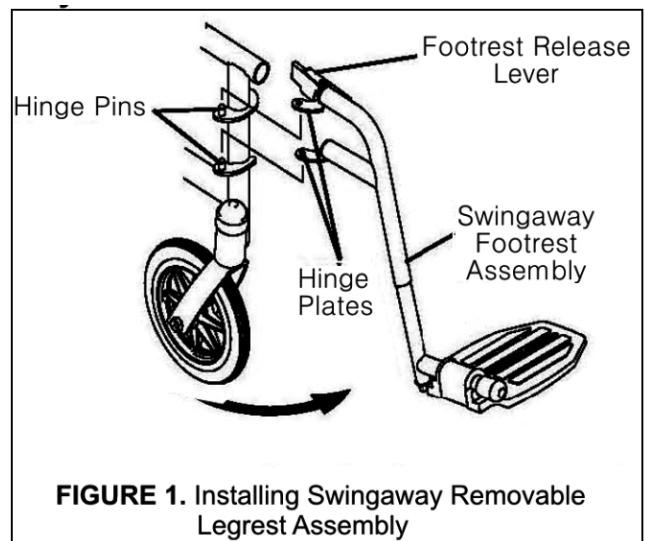

FIGURE 1. Installing Swingaway Removable Legrest Assembly

Adjusting Footplate Height

NOTE: For this procedure, refer to FIGURE 2.

1. Remove the swingaway footrest assembly.

NOTE: lay the assembly on a flat surface to simplify this procedure.

2. Loosen, but DO NOT remove, the footplate mounting bolt until the footplate assembly moves freely.
3. Reposition the footplate assembly to the desired height.
4. Securely tighten the footplate mounting bolt.
5. Repeat this procedure for the other footrest, if necessary.
6. Reinstall the swingaway footrest assembly.

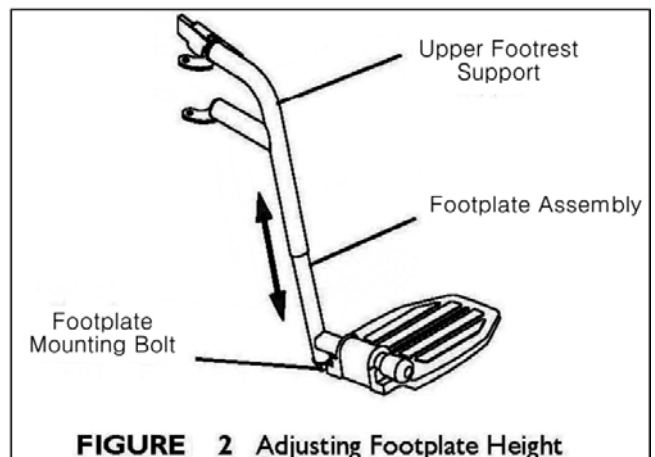

FIGURE 2 Adjusting Footplate Height

 **WARNING**

After any adjustments, and before use, make sure all attaching hardware is tightened securely. Otherwise, injury or damage may result.

Locking / Unlocking / Using Hand Brakes

Locking Hand Brake

NOTE: For this procedure refer to FIGURE 3.

1. Push down on the bottom portion of the brake handle until an audible click is heard.

Unlocking Hand Brake

NOTE: For this procedure refer to FIGURE 3.

1. Pull up on the top portion of the brake handle to release.
2. Release the brake handle.

Using Hand Brake

NOTE: For this procedure refer to FIGURE 3.

1. Pull up on the top portion of the brake handles toward the push handles.
2. Do one of the following:
 - Remain stationary—Hold the brake handle up.
 - Continue mobility—Release the brake handle.

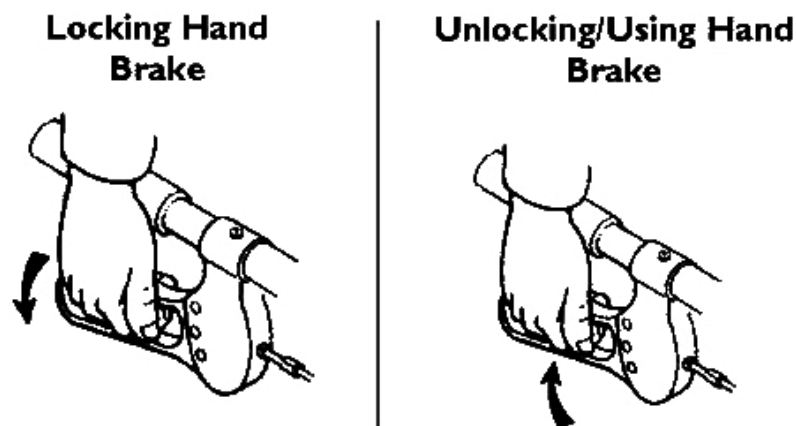

FIGURE 3. Locking/Unlocking/Using Hand Brakes

OPERATION

Adjusting Hand Brakes

NOTE: Counterclockwise / clockwise directions are determined by standing behind the Transport Wheelchair (user's position)

Adjusting Brake Handle

NOTE: For this procedure refer to FIGURE 4.

NOTE: Test brake handle. Observe how the brake lever engages the wheel. If the tension of the brake is too loose or too tight, adjust using the following steps:

1. Loosen the brake handle adjustment nut by turning clockwise.
2. Perform one of the following:
 - Loosen brake handle tension—Turn the brake handle nut clockwise.

NOTE: If the brake lever is scraping the rear wheel, the brake handle must be loosened.

- Tighten brake handle tension—Turn the brake handle nut counterclockwise.

NOTE: If the brake lever does not respond quickly, tighten brakes.

3. Turn the brake handle adjustment nut counterclockwise to secure in place.
4. Do one of the following:
 - Acceptable tension—Repeat STEPS 1 to 3 for opposite side, if necessary.
 - Unacceptable tension—Repeat STEPS 1 to 3.

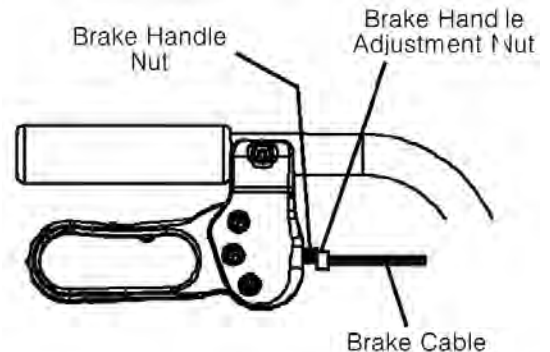

FIGURE 4. Adjusting Brake Handle

Adjusting Cable Adjuster Unit

NOTE: For this procedure refer to FIGURE 5.

NOTE: Test the brake with the brake handle. Observe how the brake lever engages the wheel. If the tension of the brake handle is still too loose or too tight, adjust using the following steps:

1. Ensure brake handle is not locked.
2. Do one of the following:
 - To loosen: Brace the lock nut while turning the adjustment screw clockwise.
 - To tighten: Brace the lock nut while turning the adjustment screw counterclockwise.
3. Repeat with the other brake.

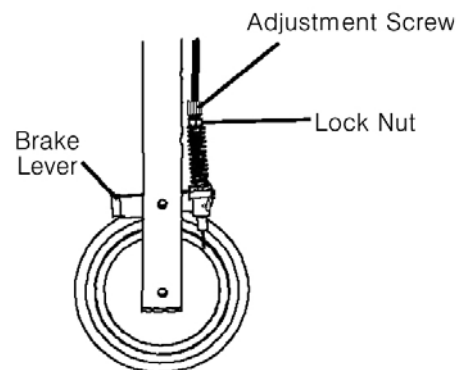

FIGURE 5. Adjusting Cable Adjuster Unit

Adjusting Wheel Lock

NOTE: For this procedure refer to FIGURE 6.

1. Loosen the bolt and locknut that secure the wheel lock assembly to the Transport Wheelchair frame.
2. Adjust the position of the wheel lock until the measurement between the rear wheel and the wheel lock shoe is between 4mm and 8mm.
3. Securely tighten the bolt and locknut.
4. Engage the wheel lock.
5. Push against the transport chair and determine if the wheel lock engages the wheel lock shoe enough to hold the Transport Wheelchair.
6. Repeat the above procedures until the wheel lock holds the Transport Wheelchair.
7. Repeat STEPS 1 to 6 for the opposite wheel lock.

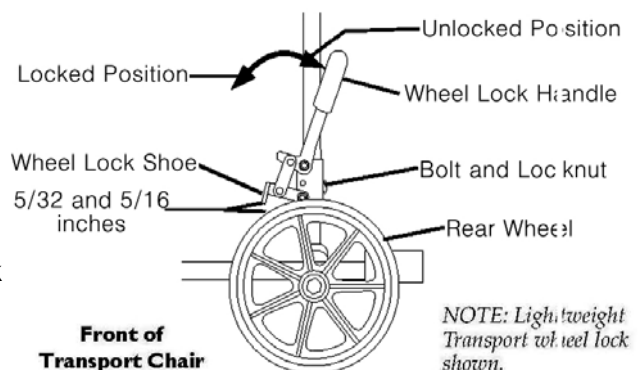

FIGURE 6. Adjusting Wheel Lock

MAINTENANCE

WARNING

After any adjustments, and before use, make sure all attaching hardware is tightened securely. Otherwise, injury or damage may result.

Unfolding / Folding the Fold-Down Back

NOTE: For this procedure refer to FIGURE 7.

Folding

1. Disengage the release mechanism on the back frame tubes.
2. Push the handles down.

Unfolding

WARNING

When unfolding the back, ensure all occupant's and/or assistant's body parts are away from the folding mechanism. Otherwise, pinching and injury may occur. Make sure the release levers are securely locked in place before using the transport wheelchair.

1. Pull up on the two back frame tubes until the release mechanisms lock in place.

NOTE: There will be an audible click.

2. Pull on the handles to make sure the back is locked in place.

Replacing Back Upholstery

NOTE: For this procedure, refer to FIGURE 8.

1. Remove the screws and washers that secure the existing back upholstery to the back frame tubes.
2. Position new back upholstery on the back frame tubes.
3. Securely tighten the new back upholstery to the back frame tubes with the screws and washers.

Replacing Seat Upholstery

NOTE: for this procedure, refer to FIGURE 9.

1. Remove the screws that secure the existing seat upholstery to the crossbraces.
2. Remove the existing seat upholstery from the crossbraces.
3. Securely tighten the new seat upholstery to the crossbraces with the screws.

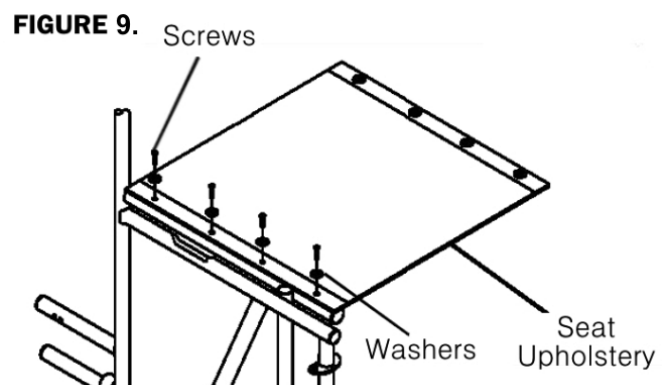
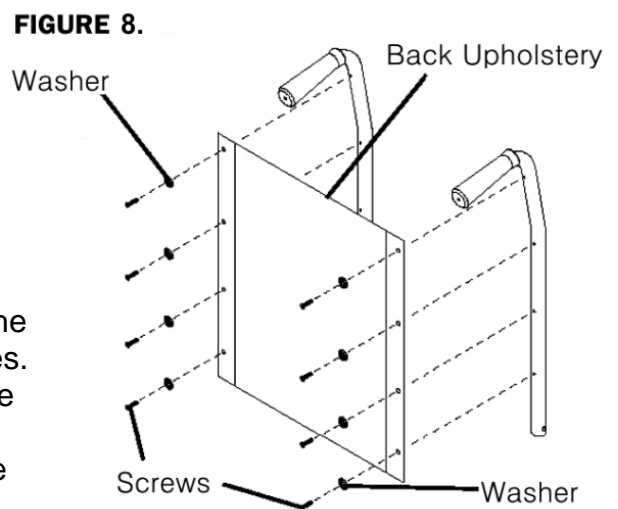
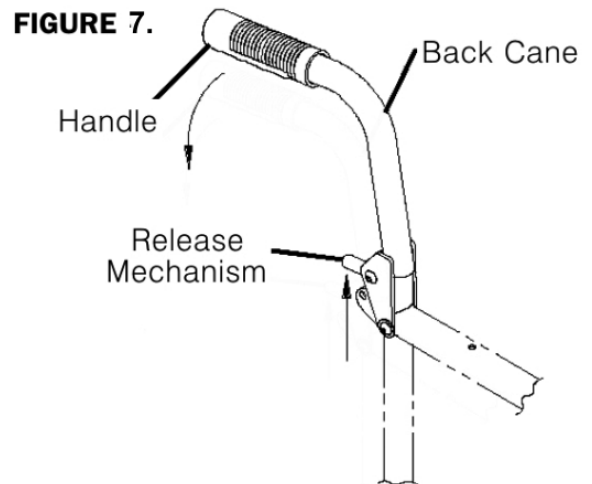

MAINTENANCE

WARNING

After any adjustments, and before use, make sure all attaching hardware is tightened securely. Otherwise, injury or damage may result.

CAUTION

As with any vehicle, the wheels and tyres should be checked periodically for cracks and wear, and should be replaced when necessary.

Replacing / Adjusting Front Forks

NOTE: For this procedure, refer to FIGURE 10.

Replacing

1. Remove the castor from the fork.
2. Remove the dust cover.
3. Remove the locknut and nylon washer that secure the fork to the castor head-tube.
4. Drop the fork out of the castor head-tube.
5. Slide the new fork into the castor head-tube and reassemble by reversing STEPS 1 to 4.
6. Adjust the forks.
7. Repeat STEPS 1 to 6 for the opposite fork, if necessary.

Adjusting

1. Remove the dust cover.
 - A. To properly tighten the castor journal system and guard against flutter, perform the following check:
 - B. Tip the transport wheelchair back to the floor.
 - C. Simultaneously pivot both forks and castors to the top of their arc.
 - D. Let the castor drop to the bottom of the arc (wheels should swing once to one side, then immediately rest in a straight downward position).
 - E. Adjust the locknuts according to freedom of the castor swing.
 - F. Test the transport wheelchair for manoeuvrability.
 - G. Readjust the locknuts if necessary, and repeat STEPS C & F until correct.
 - H. Snap the dust cover over the locknut.

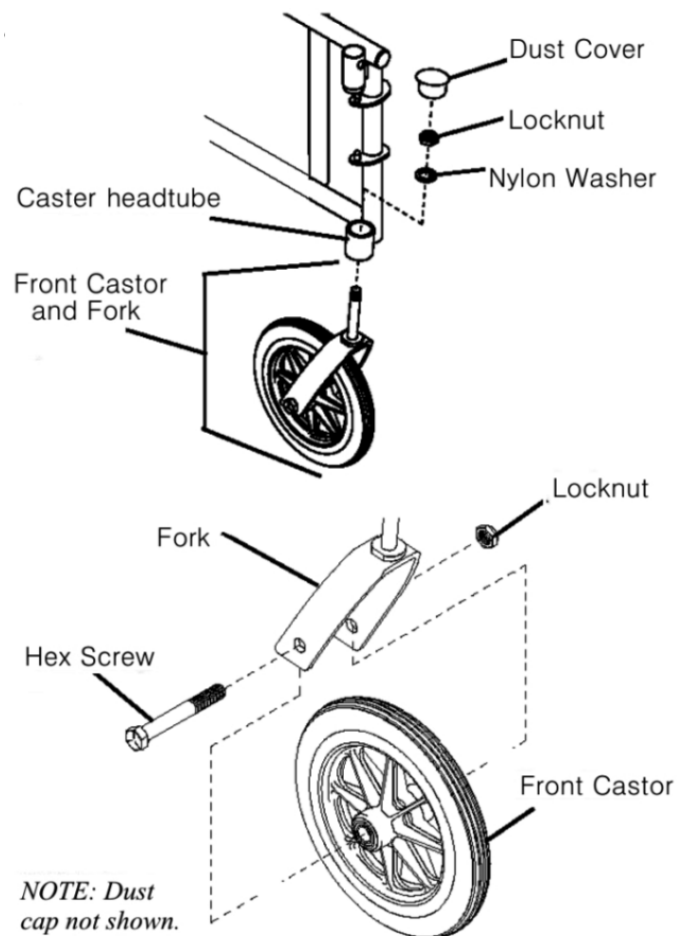

FIGURE 10. Replacing Front Casters

Replacing Front Castors

NOTE: For this procedure, refer to FIGURE 10.

1. Remove the hex screw, washers and locknut that secure the front castor to the fork.
2. Reverse STEP 1 to install new front castor.
3. Repeat STEPS 1 & 2 for the opposite front castor.

MAINTENANCE

WARNING

After any adjustments, and before use, make sure all attaching hardware is tightened securely. Otherwise, injury or damage may result.

CAUTION

As with any vehicle, the wheels and tyres should be checked periodically for cracks and wear, and should be replaced when necessary.

Removing / Installing Rear Wheels

NOTE: For this procedure, refer to FIGURE 11.

1. Remove the dust cap (if applicable), hex screw and locknut that secure the rear wheel and axle spacer to the Transport Wheelchair.
2. Repeat STEP 1 for the opposite rear wheel.
3. To reinstall the rear wheels onto the Transport Wheelchair, reverse STEPS 1 to 2.

NOTE: Make sure the axle spacer is between the rear wheel and the Transport Wheelchair frame.

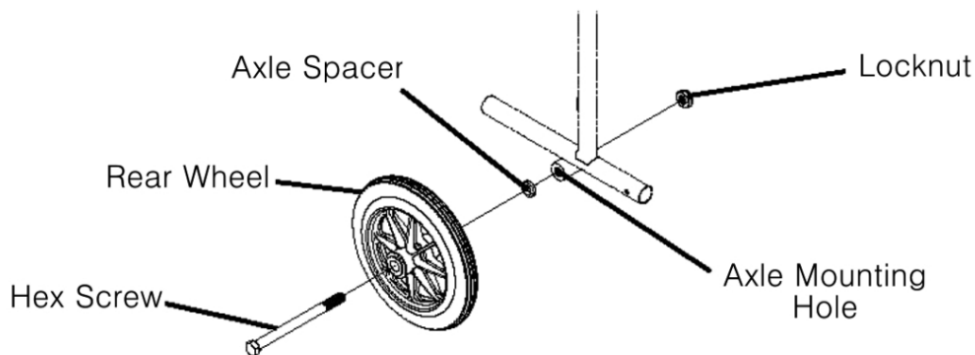

FIGURE 11. Removing / Installing Rear Wheels

PARTS LIST

LM9712 Wheelchair Parts List

No.	Code	Description
1	LM9712HG	Handgrip
2	LM9712HG	Handgrip
3	LM9712BR	Backrest
4	LM9712HHF	Hex Head Fastner
5	LM9712W	Hex Head Plastic Washer
6	LM9712SB	Seat Belt
7	LM9712AR	Armrest Pad RH
8	LM9712ARHHF	Armrest Hex Head Fastner
9	LM9712ARB	Armrest button Assembly
10	LM9712B	Brake
11	LM9712HHF	Hex Head Fastner
12	LM9712S	Seat
13	LM9712HHF	Hex Head Fastner
14	LM9712W	Hex Head Plastic Washer
15	LM9712RA	Rear Axle Assembly
16	LM9712BW	Rear Wheel 8"
17	LM9712FA	Front Axle Assembly
18	LM9712FW	Front Wheel 8"x2"
19	LM9712F	Fork Assembly
20	LM9712FC	Fork Assembly Cover
21	LM9712LS	Leg Strap
22	LM9712FRLH	Plastic footrest LH
23	LM9712FRRH	Plastic footrest RH
24	LM9712FRC	Plastic footrest cover
25	LM9712FBR	Folding Backrest Assembly
26	LM9712FBRN	Folding Backrest Nut
27	LM9712BG	Brake grip
28	LM9712BC	Brake Cable Assembly
29	LM9712AK	Brake cable adjusting knob top
30	LM9712BCAS	Brake cable adjusting spring

1. Evocare provides consumers with the following warranty in relation to this Product, in addition to complying with the requirements of any relevant legislation, including the *Competition and Consumer Act 2010* (Cth) in Australia and the *Consumer Guarantees Act 1993* in New Zealand (the Acts), except where a New Zealand consumer acquires the Product for the purposes of a business.
2. In this warranty, we have used the following definitions:
 - (a) **Form** means a warranty claim form issued by Evocare in respect of Products;
 - (b) **Evocare** or **our** means Evocare Australia Pty Limited, ABN 98 078 566 604 of Level 19, 144 Edward Street, Brisbane 4000;
 - (c) **Products** means the goods manufactured for Evocare (including products manufactured by its contract manufacturers);
 - (d) **Material** means a material or component used by Evocare in the manufacture of the Products;
 - (e) **Retailer** means the authorised dealer of Products from whom the Product was purchased;
 - (f) **Warranty Period** means the warranty period commencing from the date of purchase of the relevant Product. If the Product or part (as the case may be) is repaired or replaced, there will be no extension to the original warranty period; and
 - (g) **Workmanship** means the handling, assembly and manufacturing processes performed by or on behalf of Evocare in order to manufacture the Products.
3. Evocare warrants that for the duration of the Warranty Period, all Products will be free of faults arising from defects in Workmanship or Materials, on the terms and conditions set out in this warranty.
4. Evocare undertakes that if during the Warranty Period any Product, or any part of a Product, has failed to operate correctly due to faulty Workmanship or defective Material, it will repair or replace the Product or part (as the case may be) free of charge provided that the following procedures are met :
 - (a) The consumer must contact the Retailer or Evocare upon becoming aware of any defect to a Product upon which the consumer will be required to complete a Form and provide satisfactory proof of purchase.
 - (b) Evocare will review the Form to determine whether there is a defect, and if so Evocare agrees to (at its option) repair, replace or supply equivalent goods, or pay the cost of any of those remedies to the consumer.
 - (c) If Evocare requests the return of the applicable Product or part, the consumer will be responsible for the collection and freight costs of returning that Product or part to Evocare.
 - (d) The consumer acknowledges that it is also responsible for the freight costs to deliver any new Product or replacement part to it.
5. This warranty is in addition to any non-excludable legal rights or remedies conferred on the consumer under any applicable Act and any similar laws. To the extent permitted by law, Evocare's liability for any non-excludable condition or warranty is limited to rectifying any defect at its option, as set out in paragraph 4(b).
6. Subject to the requirements of any applicable Act or legislation and to the extent permitted by law, no liability (whether expressed or implied) of any nature whatsoever, is accepted by Evocare for any consequential loss, damage or injury arising as a result of any fault in the Products.
7. This warranty does not extend to damage to Products which occurs during transit or transportation, or which is caused by any abuse, accident or improper installation, connection, use, adjustment or repair or use of goods otherwise than in accordance with instructions issued by Evocare.
8. The warranty on Products is waived if any addition or attachment to the Products do not have Evocare's approval or are not sold as Evocare products. The Products are designed to perform specific tasks under established test loads and unauthorised attachments may produce stresses for which the design is not appropriate.
9. The following applies to consumers who purchased a relevant Product in Australia:
Our goods come with guarantees that cannot be excluded under the Australian Consumer Law. You are entitled to a replacement or refund for a major failure and compensation for any other reasonably foreseeable loss or damage. You are also entitled to have the goods repaired or replaced if the goods fail to be of acceptable quality and the failure does not amount to a major failure.

Your Evocare Transport Wheelchair is warranted to be free of defects in material and workmanship for 12 months, for the original consumer.

This warranty does not cover device failure due to owner misuse, negligence, or normal wear and tear.

The warranty does not extend to non-durable components such as rubber accessories, brakes and grips, which are subject to normal wear and tear. Non-durable components are warranted for 3 months.

For more information about your LM9712 Transport Wheelchair, warranty or to order parts call 07 3355 8007.

E- mail: sales@evocare.com.au
Website www.evocare.com.au

Manufactured for:

Evocare Australia Pty Limited, 260 South Pine Road, Enoggera. QLD. 4051.

Phone: 07 3355 8000

FAX: 07 3355 5043