

KH 600 MOBILE SHOWER TROLLEY

PATIENT CAPACITY : 150 Kg



OPERATING, MAINTENANCE & CLEANING MANUAL



n° 89726



A  Hills Company
KEIM-007

INDEX

	PAGE
SPECIFICATIONS	3
SPARE PARTS	4-5
WARNING	6
<u>HIGH/LOW OPERATION</u>	
HYDRAULIC PUMP	7
DROPSIDE RAIL	7
DRAIN HOSE	7
TRACK LOCK CASTOR	7
TOTAL LOCK CASTOR	7
<u>LUBRICATION</u>	
CASTORS	8
DROP SIDE RAIL	5
PIVOT POINTS	8
CLEANING	9
REPAIRS	9
WARRANTY & SERVICE CONTRACT	9

SPECIFICATIONS

<u>Patient Capacity:</u>	150 Kg's Max
<u>Dimensions:</u>	Length 1850mm Width 650mm High/Low position 500mm - 955mm
<u>Construction:</u>	Mild Steel frame with stainless steel push handles and side rails.
<u>Finish:</u>	All mild steel parts are pre-zinc treated and epoxy powder coated Stainless steel hinge side rails (easy transfer from hospital bed) Stainless steel push handles
<u>Hydraulic Hi-Low:</u>	Foot operated high -low hydraulic pump.
<u>Castors:</u>	175mm Dia heavy duty swivel, non-marking grey rubber castors 3 off total lock, 1 off track lock
<u>Liner:</u>	Hygienic heavy duty padded vinyl
<u>Features:</u>	Proven reliability Separate footpedals for raising and lowering Large non-slip footpedals Full wrap around bumper Hygienic heavy duty padded vinyl mattress and headrest Operate high/low from both sides of the

bed

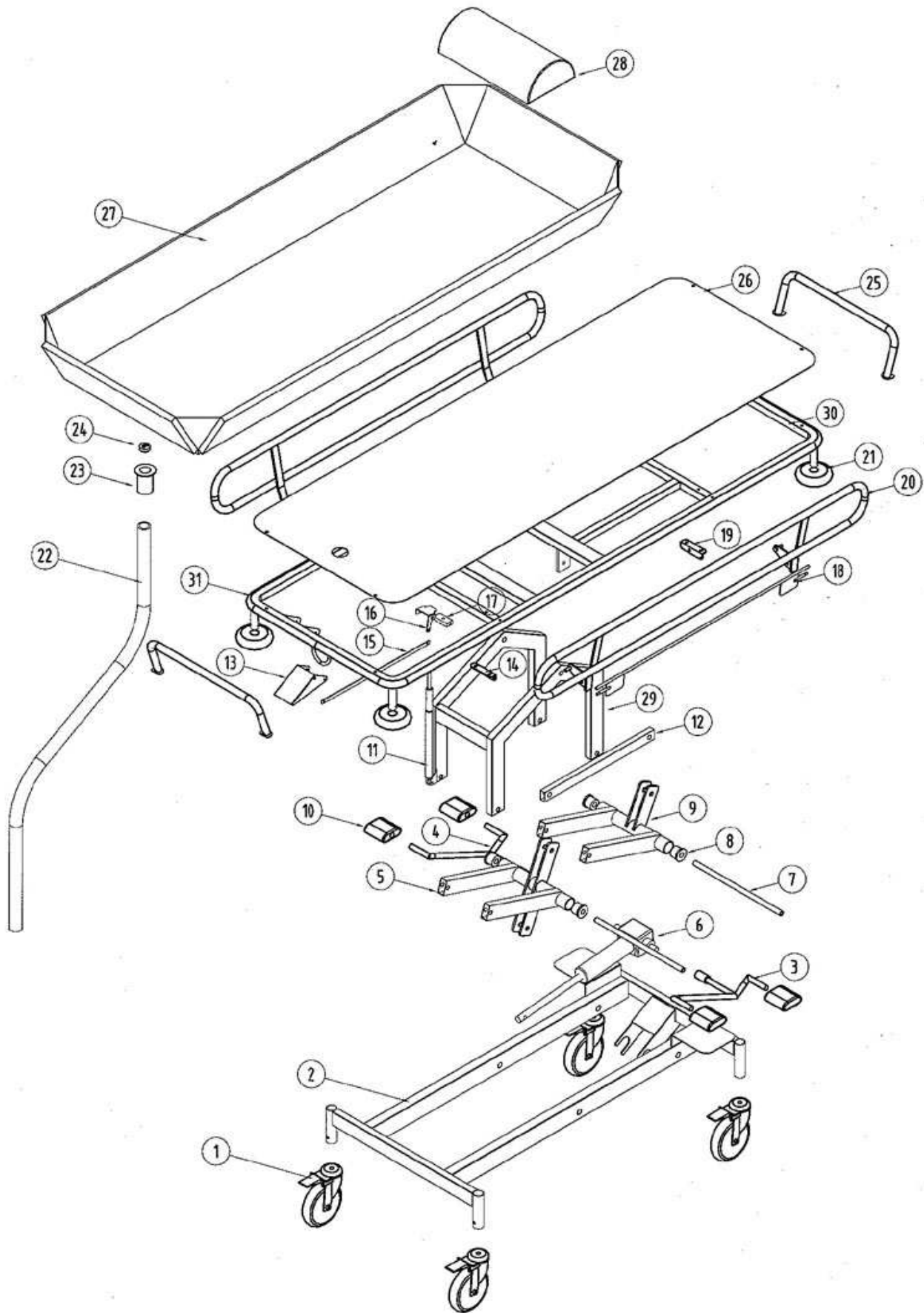

REPLACEMENT PARTS

1.	7GBBSO28R	Ø175 G/Rubber T/Lock SP28RND
2.	Base Frame	
3.	608FPA	Foot pedal arm (right)
4.	608FPA	Foot pedal arm (left)
5.	Crank (A)	
6.	608HP	Hydraulic pump
7.	600AX	Axle
8.	600BB	Brass bush
9.	Crank (B)	
10.	600F	Rubber footpedal
11.	608GS	Gas lift
12.	Crank link rod	
13.	608THL	Handle lever
14.	6088DSRLB	Drop side rail left bracket
15.	608TBFB	Trendelenburg F/Bar
16.	608GSAM	Gas spring mechanism
17.	608TBFB	Trendelenburg F/Bar
18.	Drop side rail latch	
19.	600DSRRB	Dropside rail right bracket
20.	Drop side rail	
21.	BUFF4R25	Buffer disc
22.	600H	Hose 1.5m long.
23.	KH600W	Waste housing
24.	KH600W	Plug
25.	Push handle	
26.	Top sheet	
27.	KH60L	Shower liner
28.	KH60P	Pillow
29.	A Frame	
30.	Top frame	
31.	PVCBUMP	25mm PVC Bumper rail

WARNING

IMPORTANT SAFETY PRECAUTIONS.

1. The KH 600 has been designed and manufactured with safety and function for both the patient and the carer as the utmost importance. The recommended max load rating for the trolley is 150Kg.
2. Users must read and follow the manual to ensure all safety precautions are not compromised.
3. The trolley should always to have a mattress present when in use with a patient.
4. For safety precautions when lowering the trolley to its lowest position the operator should first check to see if any obstructions are removed from under the trolley. The Trendelenburg should be in a neutral position (ie. the trolley to be level).
5. For safety precautions when side transferring a patient on/off the trolley the operator must have: -
 - (i) The brakes on the castors.
 - (ii) The Trendelenburg in a neutral position (trolley level).
6. Never have any loose objects in the vicinity of the trolley when using any of the functions, as these may snag with the moving components of the trolley. Always check the surrounding area and under the trolley for any objects that may be crushed with any movement of the trolley.
7. When the trolley is to be moved the directional lock castor can be engaged as this helps in steering the trolley. This also reduces the effort of the operator thus reducing back injuries.

OPERATING & MAINTENANCE INSTRUCTIONS

To ensure that all the safety features of the product are not compromised please read the following instructions carefully.

1 HYDRAULIC PUMP

The hydraulic pump is fully sealed die cast double action design which is extremely easy to use.

TO RAISE THE BED

- (1) Identify the 2 "raise" foot pedals located on either side of the shower trolley.
- (2) Apply smooth even strokes (Approx. 230mm in length) to the "raise" foot pedal. (fig 1)

Fig 1.



Fig 2.



TO LOWER THE BED

- (1) Identify the 2 “lower “ foot pedals located on either side of the shower trolley.
(fig 2)
- (2) Simply depress the foot “lower” pedal slowly to the bottom of it’s stroke and hold it in that position until the desired height is reached.(“Warning” – When depressing the foot pedal DO NOT stand on it with both feet, this is very dangerous and will NOT increase the speed of the operation.)

2 DROP SIDE RAILS

For ease of transfer of patient from hospital bed to shower bed the drop side rail can be lowered and swung underneath to enable the trolley to butt up against the hospital bed without a gap. The liner flap can be used to assist filling any gap between the side of the bed and mattress.

TO LOWER THE SIDE RAIL

Use a push/pull action on either on of the two (2) plated on each. This will disengage the mechanism and the rail can be lowered. Please see (fig 3).

Fig 3.



Fig

4.



To lock the side rail back into position, lift the rail from underneath the bed and it will automatically “clip “ into position.

3. DRAIN HOSE

The drain hose can be easily inserted by screwing on the waste outlet. There are no clips or locks and it can be removed unscrewing hose. Please see Fig 4

4. CASTORS

The KH600 is equipped with three (3) 175 mm Dia heavy duty locking castors and one 175 mm Dia heavy duty Track lock castor.

The Track Lock (Green lever fig 5.) is useful for transporting patient from ward to bathroom, as once engaged the bed can be pushed and steered from the drain end whilst tracking in a straight line. When the Directional Lock is disengaged the bed can be moved in any desired direction.

Fig 5.



Fig 6.



The Track Lock can be engaged by depressing the outer lever and disengaged by depressing the inner lever.

The three(3) Total Lock (Red lever fig 6.) castors are used to prevent the trolley from moving. These are mainly used when side transferring or during the bathing process. The Total Lock castors can be engaged to lock both the wheel and the rotation of the castor. To apply the Total Lock castor depress the outer lever and unlock by depressing the inner lever.

MAINTENANCE INSTRUCTIONS

LUBRICATION

There are only three (3) parts on the KH600 which require periodical lubrication. These are:-

1. CASTORS

The castors are the component most vulnerable to corrosion and therefore need to be lubricated monthly.

This involves:-

- 1.1 The castor head bearing is fully sealed ball race. This design does NOT require any lubrication.
- 1.2 The wheel is the only castor component that requires lubricating every month. To do this the wheel must be unbolted and removed from the castor frame. The dust covers can then be removed and TAC-2 can be sprayed into the hub to lubricate the internal bearings. (fig 7)

(fig 7) Dust cover

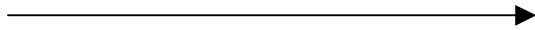

2. DROP SIDE RAILS

The drop side rail requires lubricating with TAC-2 every two (2) months

3. PIVOT POINTS

All seven (7) pivot points require lubrication monthly. Spray TAC-2 directly in between the joint. See (fig 8)

Fig 8.

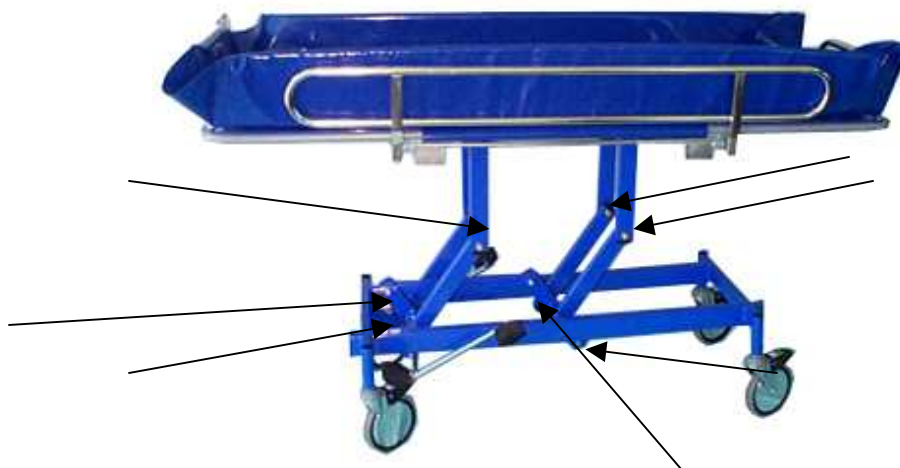

(Note: Remove all excess over spray as this may damage the epoxy coating and could be dangerous if it spills onto a hospital floor).

NOTE:

1)TAC-2 IS A CRC PRODUCT AND IS AVAILABLE FROM MOST AUTOMOTIVE OUTLETS OR THROUGH: - Kerry Equipment

CLEANING INSTRUCTIONS.

1. The KH600 Shower Trolley can be cleaned with a low strength detergent, warm water and soft textured cloth. (This includes : liner, all stainless steel and epoxy powder coated framework)

LINER REPAIR KIT

For small cuts and abrasions the liner repair kit can be used to increase the service life of the shower trolley liner. Please follow the following instructions.

1. PATCH PREPARATION

- 1.1 Cut the patch to the require size. Allow 15mm either side of cut or abrasion.
- 1.2 Radius corners of patch. (Approx. radius = 5mm) –see Fig 1.



- 1.3 Clean patch with methylated spirits

2. CUT OR ABRASION PREPARATION

- 2.1 Remove liner from shower trolley and dry
- 2.2 Clean the area to be repaired with methylated spirits
- 2.3 Open cut and squeeze in a small amount of glue
- 2.4 Close cut where possible

3. PATCH APPLICATION

- 3.1 Place glue on both patch and liner surface.
- 3.2 Place patch on cut or abrasion.
- 3.3 Smooth surface with finger.
- 3.4 Place heavy book over patch and leave overnight.

Please note that the kit is only designed to repair small cuts and abrasions.

WARRANTY & SERVICE CONTRACT

WARRANTY

The KH600 is covered under the standard Kerry Equipment 2 Year warranty policy. This covers all parts and labour but excludes freight to and from Kerry Equipment's premises.

SERVICE CONTRACT

A Kerry Equipment Technical Representative should service the KH600 annually. Contact Kerry Equipment or Distributor for further details or to arrange a Service Contract.



Kerry Equipment (Aust) Pty Ltd
ABN 71 062 784 147

4 Halley Road
Balcatta, Perth
Australia 6021

Telephone +61 8 9240 2944
Facsimile +61 8 9240 1469
email@kerryequipment.com.au

www.kerryequipment.com.au

Manufactures of
Hospital & Nursing Home Equipment