

Horizontal lifter **Body Scoop**

– Simple and dignified lift

The horizontal lifter Body Scoop is specially designed to overcome the great moving and handling challenges that mortuary staff faces every day.

Dignity and respect of the deceased is maintained, when the Body Scoop is used in combination with one of Guldmann's lifting modules.

At the same time the risks from manual handling are significantly reduced. Operation is simple and the Body Scoop requires only very limited training.

Choice of materials and design makes it easy to clean and make ready for the next lift.

The lifter is flexible and designed to handle the wide variation in size and shape of deceased.

The horizontal lifter Body Scoop is designed to be used with Guldmann's lifting modules mounted in ceiling rail systems which means they do not take up any space when the Body Scoop is not in use.



V. Guldmann A/S
Graham Bells Vej 21-23A
DK-8200 Aarhus N
Tel. +45 8741 3100
Fax +45 8741 3131
info@guldmann.com
www.guldmann.com

Horizontal lifter Body Scoop Technical specifications

Functions

Max. load : 150 kg

Weight and Materials

Total weight : 10.2 kg

Material : Rustproof steel, electropolished

Measurements

A max. : 1515 mm

A min. : 1215 mm

B : 740 mm

Labelling

The product is manufactured in compliance with the Council Directive 93/42/EEC of June 14th 1993, including amendments, as medical device class 1.

Item Number/Model

28425 : Horizontal lifter Body Scoop

Classification

According to ISO 9999 : 12 36 03

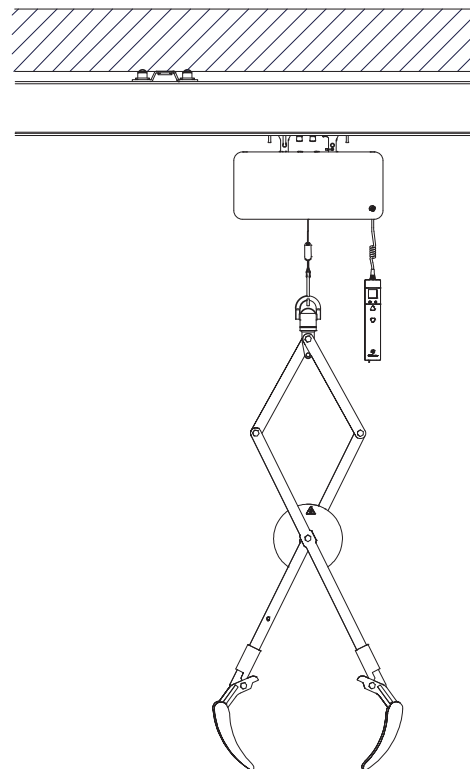
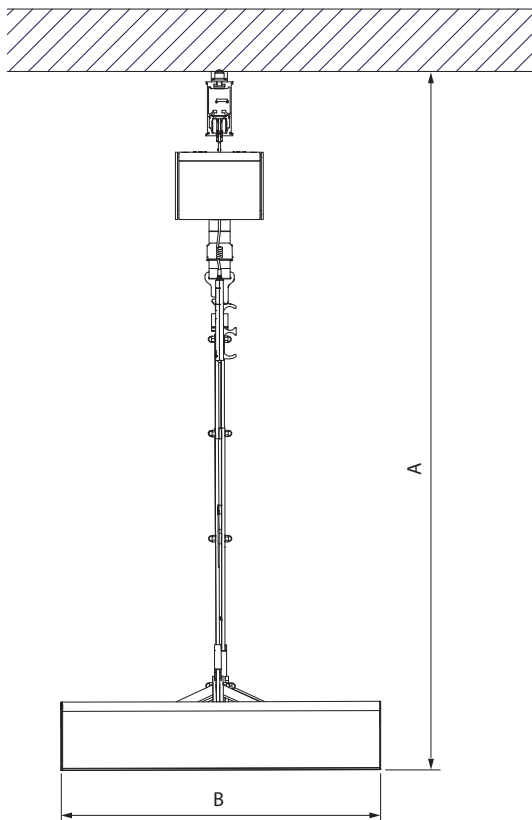

Time to care