

KH 402 HOME-CARE LIFTER



OPERATING, MAINTENANCE & CLEANING MANUAL



n° 89726



A Hills Company



www.evocare.com.au

Phone:07 33558000 Fax:07 33555043

KEIM - 012

INDEX

	PAGE
SPECIFICATIONS	2
SPARE PARTS	3-4
SAFETY PRECAUTIONS	5
OPERATING INSTRUCTIONS	5
BATTERY CHARGING AND CARE	6
MAINTENANCE INSTRUCTIONS	7
CLEANING INSTRUCTIONS	8

SPECIFICATIONS

<u>DIMENSIONS:</u>	Length	1150mm
	Width	670mm
	Height	1220mm
	Effective lift range	430mm – 1700mm
	Leg gating (inside)	510mm – 900mm
	Lift reach	700mm
	Under base clearance	25mm
	Base height	110mm
	Leg height from floor	100mm
	Turning radius	1300mm
<u>LIFT SPEED:</u>	35mm per second	
<u>LIFT DRY WEIGHT:</u>	38 Kg (with battery)	
<u>LIFT CAPACITY:</u>	Max load - 150kg	
<u>CASTORS:</u>	Ø125mm Total lock rear polyurethane castor Ø75mm Twin swivel grey rubber castors – front. Note: Larger castors available on request. (Easier to move)	
<u>FINISH:</u>	Epoxy powder coated Polyurethane yoke	
<u>ELECTRICAL ITEMS:</u>	Tested by Linak Australia to standards:- - AS 3108-1990 - AS 3200.1-1990	

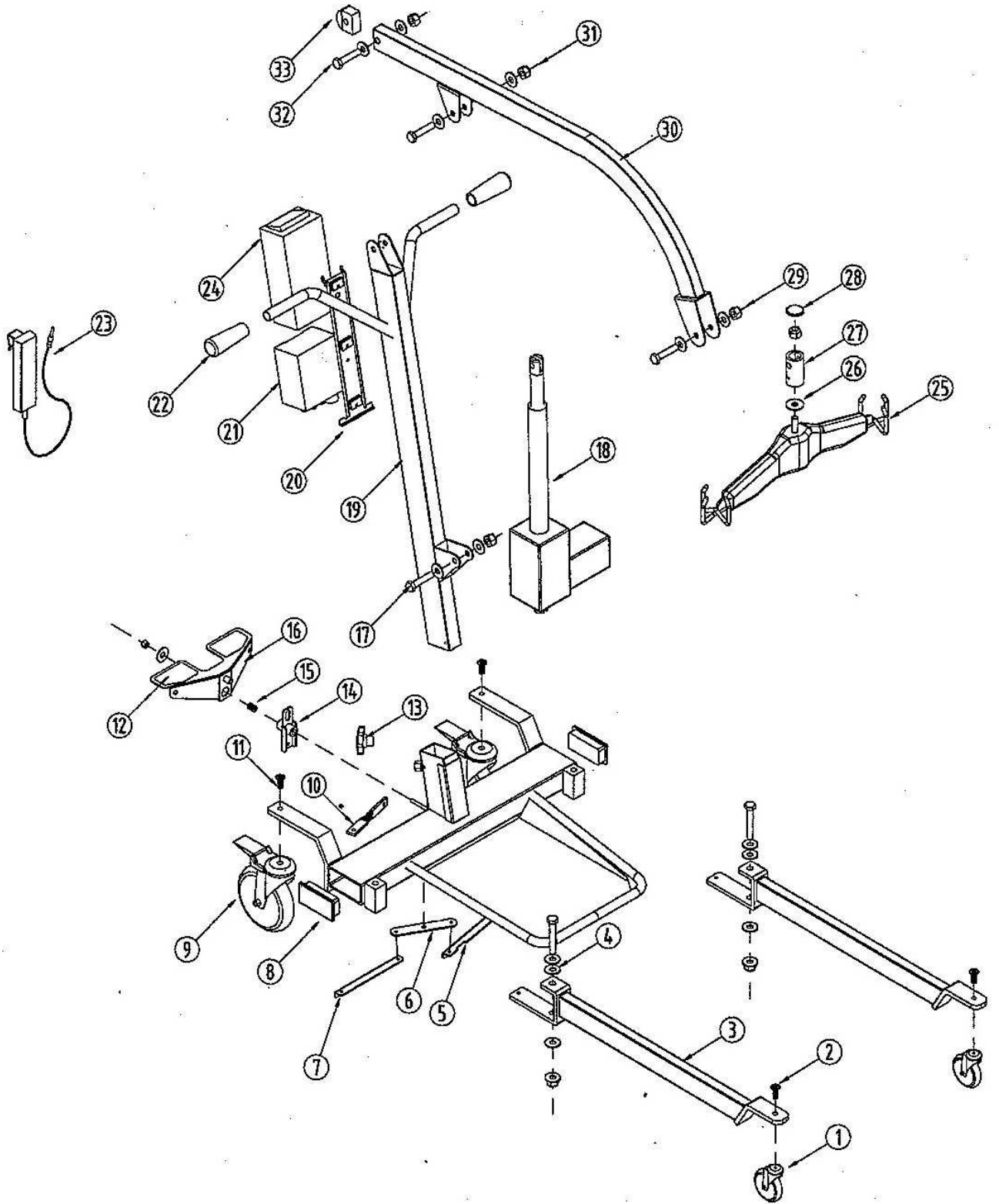

ITEM	PART NUMBER	DESCRIPTION
1	3PUSB10M	Ø75 POLY SINGLE WHEEL SWIVEL CASTOR
2	ZMCS711	FRONT CASTOR BOLT
3	KH400-GE 05	LEG ASSEMBLY
4	ZH820	LEG PIVOT BOLT KIT
5	40TRL	LARGE TIE ROD
6	400GE-07	TIE ROD PIVOT BRACKET
7	40TRS	SMALL TIE ROD
8	P10050	BASE END CAPS 100X50
9	5GTBB10M	Ø125 G/R T/LOCK BH M10
10	400GE-11	FOOT PEDAL TIE ROD
11	ZH711	REAR CASTOR BOLT
12	SAFETYWALK	FOOT PEDAL GRIP DECK
13	3/8MTRI	3/8 MALE TRI WHEEL
14	400GE-06	FOOT PEDAL PIVOT LEVER
15	CS002	FOOT PEDAL SPRING
16	400GE-06	FOOT PEDAL
17	ZH816M	LOWER ACTUATOR MOUNT KIT
18	LA34.3 100+3L	300mm LIFT ACTUATOR SINGLE SPEED
19	402-01	MAST ASSEMBLY
20	MBJ2	MOUNT BRACKET CONTROLLER AND BATTERY
21	CBJ2-00-00NA001010	SINGLE SPEED CONTROLLER
22	608PHG	PUSH HANDLE GRIPS
23	HB51B-00-01	SINGLE SPEED HAND SET
24	BAJ2-00-01	BATTERY
25	40YE	YOKE
26	NFW8383	YOKE PIVOT WASHER
27	40YTB	YOKE TOP BUSH
28	P76911/8	END CAP
29	HTHH811	YOKE PIVOT BOLT KIT
30	402-05	ARM ASSEMBLY
31	ZNN8M	TOP ACTUATOR MOUNT KIT
32	ZH816M	ARM PIVOT BOLT SET
33	PRC5025	RADIUS END CAP

SAFETY PRECAUTIONS.

1. The Home – Care hoist is manufactured and tested with safety and function for the carer and patients as the utmost importance.
2. The **MAXIMUM** safe working load is **150 Kg's**.
3. **EMERGENCY LOWERING:** The emergency lowering button can be used to lower the hoist if there is a handset failure. The switch is located on the controller under the big red emergency stop switch. Simply press using a ballpoint pen or similar object, **DO NOT** use a sharp object such as a compass point.
4. Always use the correct slings on the hoist.
5. For safety precautions only properly trained personal should use the hoist.

OPERATING INSTRUCTIONS

BATTERY PACK INSTALLATION

Simply locate the battery on the mounting bracket and clip the release lever into the secure position. The Hoist is now ready for use.

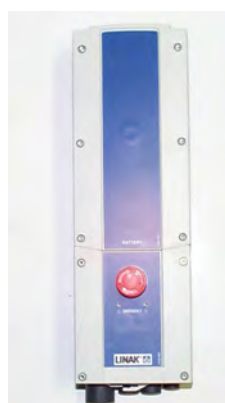

HANDSET: - RAISE/LOWER:

The hoist operates via a hand controller. To raise or lower the hoist, simply press the required switch on the touch pad.

LEG GATING:

To **OPEN** or **CLOSE** the “Gate” on the legs, simply press the foot pedal to open or close the legs.

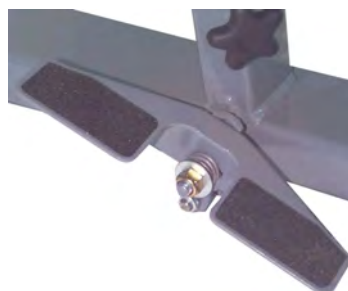

YOKE - SLING MOUNTING POINTS

Refer to the fitting instructions supplied with the sling.



BATTERY CHARGING AND CARE

CHARGING:

Before the hoist can be operated the battery pack will need to be charged. Minimum 4 hours for flat battery.

Please follow the instructions below.

Plug the charger unit into the 240 Volt supply outlet. The unit is now ready to accept a battery that requires charging.

To charge the battery, simply locate the charging plug securely into the female socket on the base of the battery.

If a two-battery system is going to be used, replace the first battery once charged, with the second battery. Charge as above.

NOTE: A battery pack may remain on charge indefinitely without any detrimental effects to the battery or charging unit.



BATTERY CARE:

The hoist uses fully sealed lead acid batteries. They are made to be recharged on a regular basis. To care for your batteries and obtain the maximum life **DO NOT** allow the batteries to run totally flat before recharging.

The controller is fitted with an **audio low battery warning alarm**. When this warning alarm sounds complete the lift process, then change the battery and recharge. Kerry Equipment recommends that a 2-battery system be used, this allows one battery to always be on charge while the other is in use, and hence the hoist may never be out of service with a flat battery.

MAINTENANCE INSTRUCTIONS

The hoist requires periodical lubrication. These points are:

CASTORS.

It is always best practice to remove all hair and lint from the castors as soon as possible, always allowing free movement of all the wheels.

The head bearing will need lubricating monthly. Simply spray TAC-2 up into the bearing while rotating the castor.

The wheel also requires lubricating every month. To do this the wheel must be unbolted and removed from the castor frame. TAC-2 can then be sprayed into the hub centre to lubricate the internal bearings.



BASE PIVOT POINTS and FOOT PEDAL

All pivot points will need to be lubricated regularly with TAC-2 or similar lubricant. Simply spray the points for a second or two on either side.

The hoist has to be turned onto its side for access to the following lubrication points. (To do this 2 people are required.)

Both people are to stand on one side of the hoist. One near the push handle, the other by the side of the hoist. The person near the push handle locks the total lock castors. In conjunction with one another, pull the hoist towards the side, lowering the hoist onto the floor.

You now have access to all the lubrication points under the base. i.e.: pivot points, leg lever and leg pivot. Simply spray TAC-2 on all the pivot points.

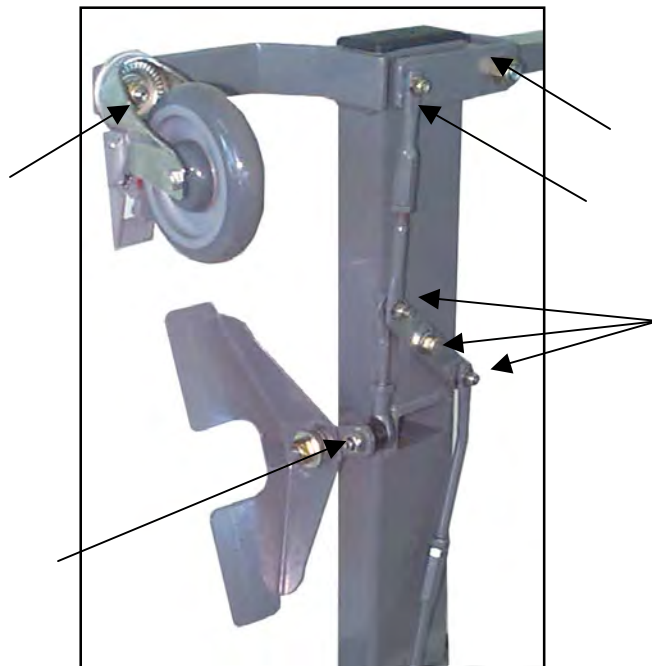

ARM AND ACTUATOR PIVOT POINTS

The arm and actuator pivot points will need to be lubricated regularly with TAC-2 or similar lubricant. Simply spray on each side of the recommended points for a second or two.



TAC-2 is a CRC product and is available from most automotive outlets or from Kerry Equipment.

KERRY EQUIPMENT NOW HAS A SERVICE VAN FOR ALL YOUR MAINTENANCE NEEDS

CALL: 08 9240 2944

CLEANING INSTRUCTIONS

1. The hoist can be cleaned with a low strength detergent, warm water and a soft textured cloth. This includes all Epoxy powder coated framework and yoke.
2. **CAUTION**
Do not immerse any parts in water.
Do not allow water/cleaning liquid to enter the battery or controller.
Clean up spills immediately.
3. **SLING CARE**
Protect from direct sunlight.
Repair any cuts or fraying immediately.
Slings are machine washable.
Please refer to care instructions on the sling.

Distributed by: -



A Hills Company

Kerry Equipment (Aust) Pty Ltd

ABN 71 082 784 147

4 Halley Road
Balcalta, Perth
Australia 6021

Manufacturers of
Hospital & Nursing Home Equipment

EVOCARE AUSTRALIA PTY LIMITED

A.B.N. 98 078 566 804

Trading as **EVOCARE** and **L&M EQUIPMENT**

P.O. Box 1144, Stafford Qld. 4053

Ph: 07 3355 8000 Fax: 07 3355 5043

Website: <http://www.evocare.com.au>

E-Mail: sales@evocare.com.au

workshop@evocare.com.au



Quality
ISO 9001